

## 2B3. Multi-purpose Coal Gasification Technology Development (EAGLE)

**Research and development:** New Energy and Industrial Technology Development Organization; J-POWER; Japan Coal Energy Center; and Babcock Hitachi K.K.  
**Project type:** Coal Production and Utilization Technology Promotion Grant; and Grant for the Development of Advanced Technology for Generation of Fuel Gas for Fuel Cell Development  
**Period:** 1995-2006 (12 years)

### Technology Overview

#### 1. Summary of technology

The purpose of EAGLE (Multi-purpose Coal Gasification Technology Development) is to reduce the environmental burden, particularly global warming gas emissions. The EAGLE project aims to establish a coal gasification system utilizing the most advanced oxygen-blown, single-chamber, two-stage swirling flow gasifier that allows the highly-efficient production of synthetic gas (CO+H<sub>2</sub>), and which can be widely used as a raw material for

chemicals, hydrogen production, synthetic liquid fuel, electric power generation and other purposes.

This gasifier, combined with gas turbines, steam turbines, and fuel cells, will provide an integrated coal gasification fuel cell combined-cycle system (IGFC) that can be expected to reduce CO<sub>2</sub> emissions by up to 30% relative to existing thermal power plants.

#### 2. Development targets and technology to be developed

The EAGLE project's development targets are shown in Table 1. When utilizing coal-gasified gas for fuel cell power generation or the production of synthetic fuel, hydrogen, or chemical fertilizers, sulfur compounds and other impurities contained in the gas may contaminate the fuel cells and the reactor catalyst, thereby degrading their performance. The EAGLE project, therefore, sets targets to meet the purity levels required by fuel cells and catalysts. Since there have been few reports published on the matter, particularly on the effects of fuel cell contaminating materials (including halogens), the project set target levels with reference to reports by the U.S. Department of Energy (DOE), the MCFC Association of Japan, and other organizations.

Table 1 Development targets

Item	Development target
Coal gasification performance	Carbon conversion rate: 98% or higher Cold gas efficiency: 78% or higher Gas calorific value (higher): 10,000 kJ/m <sup>3</sup> N or higher
Gas purification performance	Sulfur compounds: 1 ppm or less Halogen compounds: 1 ppm or less Ammonia: 1 ppm or less Dust: 1 mg/m <sup>3</sup> N
Miscellaneous	Continuous operation: 1,000 hr or longer Acquisition of gasification data for 5 or more coal types Acquisition of scale-up data

#### 3. Pilot test plant

In this project, a pilot test plant with a coal processing capacity of 150 tons/day was built on the premises of the J-POWER's Wakamatsu Research Institute. Operational testing is now underway. Figure 1 shows a flowchart of the pilot test plant and Table 2 provides the specifications of the major systems. The test

plant consists of the following systems: coal pretreatment, coal gasification, air separation, gas purification, effluent treatment, and produced gas combustion, as well as a gas turbine.

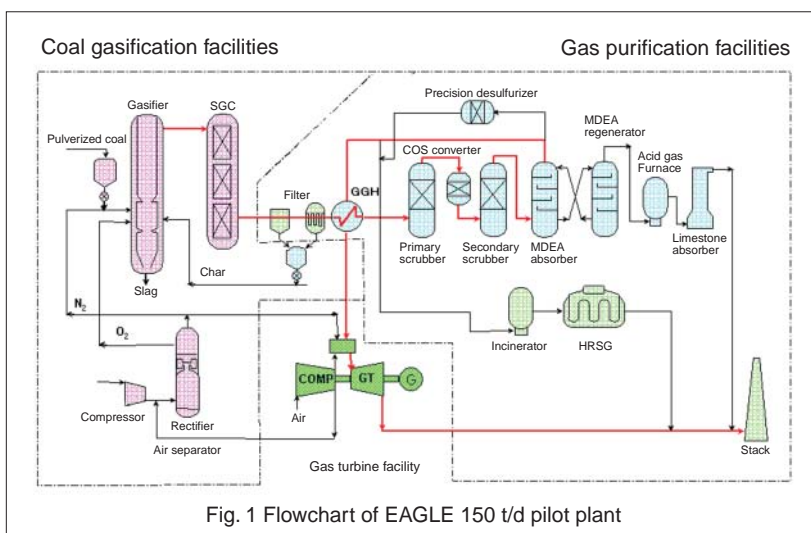

Fig. 1 Flowchart of EAGLE 150 t/d pilot plant

Table 2 Specifications of major systems

Item	Specifications
Coal gasifier	Oxygen-blown, single-chamber, two-stage swirling-flow entrained bed gasifier
Coal processing capacity	150t/d (6.3t/hr)
Gasification temperature	1,200-1,600°C
Gasification pressure	2.5MPa
Gas refinery	Wet chemical absorption type
Absorbing solution	Methyl diethanolamine (MDEA)
Processing capacity	Approx. 14,800 m <sup>3</sup> N/h
Sulfur recovery unit	Wet limestone-gypsum method
Air separation system	Pressurized cryogenic separation type
Air pressure	1.09MPa
Air processing capacity	Approx. 27,500m <sup>3</sup> N/hr
Oxygen production	Approx. 4.600m <sup>3</sup> N/hr
Oxygen purity	95%
Gas turbine	Open simple-cycle, single-shaft type
Output	8,000kW

4. Timetable and progress

This project is being promoted by a joint team from the New Energy and Industrial Technology Development Organization (NEDO) and the J-POWER. The pilot plant (150 t/d) was constructed on the premises of J-POWER's Wakamatsu Research Institute (Photo 1), and operational testing is now underway.

Table 3 Achievement of research targets

		Final target	Achievements
Coal gasification performance	Gas electric power generation	10,000 kJ/m <sup>3</sup> N or higher	10,100 kJ/m <sup>3</sup> N or higher
	Carbon conversion rate	98% or higher	99% or higher
	Cold gas efficiency	78% or higher	78% or higher
Gas purification performance	Sulfur compounds	1 ppm or less	N.D. (<1 ppm or less)
	Ammonia	1 ppm or less	1 ppm <sup>1</sup>
	Halogen compounds	1 ppm or less	1 ppm or less
	Dust	1 mg/m <sup>3</sup> N	1 mg/m <sup>3</sup> N or less <sup>2</sup>

Notes: Coal processing capacity of 150 t/d verified  
 1: at the outlet of the absorber, 2: at the outlet of the second scrubber

EAGLE development timetable

Fiscal year	1995	1996	1997	1998	1999	2000	2001	2002	2003	2004	2005	2006
F/S												
Conceptual/detailed design												
Fabrication and construction												
Operation research												

5. Future plans

Major future developments are planned for the project, including support for using multiple grades of coal, acquisition of scale-up data, technological enhancements for improved cost-efficiency, as well as system verification. With a view to achieving the development targets ahead of schedule, these challenges have already been addressed. EAGLE technology can be effectively used in integrated coal gasification combined cycle (IGCC) power generation systems, which combine gas turbine generation systems and steam turbine generation systems, or in an integrated coal gasification fuel cell combined-cycle system (IGFC). This may be the ultimate triple-combined-cycle based on combining IGCC with fuel cells. IGFC is expected to dramatically

improve generation efficiency relative to conventional pulverized coal-fired power generation systems, and is the ultimate power generation system, with power generation efficiency exceeding 55%. EAGLE plants using oxygen-blown coal gasifiers produce coal-gasified gas with a substantially lower proportion of non-CO and H<sub>2</sub> gas components (i.e., N<sub>2</sub> and other gases). Utilization of this gas allows the efficient production of liquid fuels or chemical feedstocks.

In the U.S., there is a proposed project to combine a hydrogen gas turbine generation system or a fuel cell power generation system that uses coal-derived hydrogen with a CO<sub>2</sub> separation, collection and segregation system. EAGLE technology is not only expected to meet the future demands of a hydrogen society, but is also expected to meet the demands of today.



Photo 1 Pilot test facilities

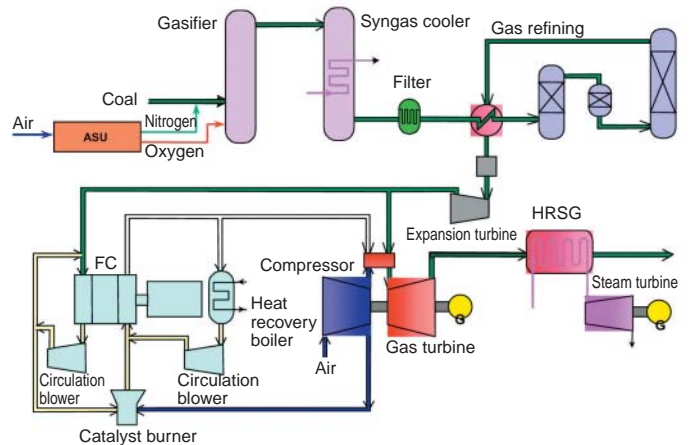

Fig. 2 IGFC system

Reference

1) Masao Sotooka: Coal Gasification Technology (II) — Multi-purpose (Fuel-cell) Coal Gasification Technology Development (EAGLE), The Japan Institute of Energy, Vol.82, No. 11, pp. 836-840, November 2003.